

PART R48**SUPPLY OF SIGNS****CONTENTS**

1. GENERAL
2. PREQUALIFICATION
3. DESIGN
4. MATERIALS FOR SIGNS
5. CERTIFICATION FROM RETROREFLECTIVE SHEETING MANUFACTURER
6. MANUFACTURE OF SIGNS
7. HANDLING OF SIGNS
8. SIGN PERFORMANCE WARRANTIES
9. VERIFICATION REQUIREMENTS AND RECORDS

Attachment R48A:	Sign Materials – Legends and Background
Attachment R48B:	Schedule of Hole and Stiffener Centre Locations
Attachment R48C:	Stiffener Joining Detail
Attachment R48D:	Sectioned Sign Joining
Attachment R48E:	Sign Identification

1. GENERAL

- .1 This Part sets out the requirements for the manufacture and delivery of all regulatory, warning, guide, information, freeway guide, direction and hazard marker signs. This Part does not cover electronic signs.
- .2 The Contractor must supply signs in accordance with the following (in order of precedence):
 1. any contract specific drawings or **Contract Specific Requirements**;
 2. the requirements of this Part; and
 3. standard drawings.
- .3 "**Standard Sign**" means a sign in accordance with AS 1743.1 or a sign detailed on the DPTI Sign Index.
- .4 Documents referenced in this Part are listed below:

AS 1163	Cold-formed Structural Steel Hollow Sections
AS 1170	SAA Loading Code – Wind Loads
AS 1214	Hot-Dip Galvanised Coatings on Threaded Fasteners
AS 1450	Steel Tubes for Mechanical Purposes
AS 1397	Continuous Hot-Dip Metallic Coated Steel Sheet and Strip - Coatings of Zinc and Zinc Alloyed with Aluminium and Magnesium
AS 1580	Paints and Related Materials - Methods of Test
AS 1627	Metal Finishing - Preparation and Pre-treatment of Surfaces
AS 1627.1	Metal finishing - Preparation and Pretreatment of Surfaces - Removal of Oil, Grease and related Contamination
AS 1627.4	Metal Finishing - Preparation and Pretreatment of Surfaces - Abrasive Blast Cleaning
AS 1734	Aluminium and Aluminium Alloys - Flat Sheet, Coiled Sheet and Plate
AS 1742.1-15	Manual of Uniform Traffic Control Devices
AS 1743	Road Signs – Specifications
AS 1744	Standard Alphabets for Road Signs
AS 1866	Aluminium and Aluminium Alloys - Extruded Rod, Bar, Solid and Hollow Shapes
AS 1906.1	Retroreflective Materials and Devices for Road Traffic Control Purposes – Retroreflective Sheeting
AS 2700	Colour Standards for General Purposes
DPTI	Standard Road Sign - Specification South Australia, - refer to online index at http://www.dteiapps.com.au/signindx/

2. **PREQUALIFICATION**

- .1 Signs must be manufactured by a company prequalified with DPTI - refer http://www.dpti.sa.gov.au/contractor_documents/prequalification

3. **DESIGN**

- .1 The design of a sign must be in the format of either a DPTI Traffic Engineering Specification (TES) drawing or a standard drawing prefixed similar to the Australian Standard series; e.g. R1-2.
- .2 The dimensions, legend and background for each sign must be in accordance with:
 - (a) Specific Road Signs – Specifications, South Australia (TES drawing)
 - (b) AS 1743
 - (c) AS 1744
 - (d) Standard Road Sign – Specification South Australia

4. **MATERIALS FOR SIGNS**

Sign Blanks

Metallic Sign Blanks

- .1 Metallic sign blanks must be manufactured from an aluminium alloy with a thickness of either 1.6 mm or 2.0 mm. The aluminium alloy must be grade 5052 or 5251, temper H36 or H38 as specified in AS 1734. Sign blanks must be free of cracks, tears and other surface blemishes and the edges must be true and smooth.

Non-Metallic Substrate Sign Blanks

- .2 The Principal is trialling the use of non-metallic substrates for a limited range of signs and may permit, at its sole and unfettered discretion, the use of a non-metallic substrate. Any such sign blanks must:
 - (a) be no larger than 600 mm x 900 mm for signs from the Australian Standard series, as defined in the DPTI Standard Road Sign Index;
 - (b) be no larger than 1200 mm x 900 mm for flat panel temporary warning signs or 1800 mm x 600 mm for temporary warning signs having a polycarbonate extruded edge i.e. box edge signs, as defined in the DPTI Standard Road Sign Index;
 - (c) comply with the provisions of AS1743 Clause 11.1;
 - (d) be compatible with the material with which they will be covered;
 - (e) be constructed of Polycarbonate or other approved UV stable product to guarantee an outdoor service life of at least 15 years;
 - (f) be flexible, non-shattering and not subjected to fatigue cracking;
 - (g) have a nominal thickness of 3 mm;
 - (h) be smooth, free of cracks, surface blemishes, and all edges must be true and smooth for the life of the product; and
 - (i) not void the warranty given by the manufacturer of any sheeting or coating applied to the substrate;
- .3 Non-metallic substrates must only be used in areas where there is a high probability of vehicle impact and the Principal's written approval is obtained beforehand.

Stiffeners

- .4 Stiffeners must be continuous horizontal lengths of galvanised cold rolled steel channel with cross-sectional dimensions of 41.3 x 21.0 mm or aluminium extruded section with cross-sectional dimensions of 28.5 x 25.5 mm.
- .5 Each stiffener section must have internal clamping ridges compatible with the Unistrut Pipe and Tubing Clamping system. A minimum overlap length of 1000 mm is required when joining stiffeners on a multi-piece sign, as shown in Attachment R48C.

Rivets

- .6 Rivets must be from a self-piercing riveting system or conform to the following requirements:

- (a) 1 320 N minimum shear load;
 - (b) 1 910 N minimum tensile load;
 - (c) Aluminium alloy with a steel stem and domed head;
 - (d) 4.8 to 5 mm shank diameter; and
 - (e) 8.5 to 9.5 mm head diameter.
- .7 The riveting process must not project above the surface of the sign blank in a manner which will result in damage of the sign face material. The heads of rivets must be coloured to match the surrounding material.

Backing Strips

- .8 Backing strips must be the same material and condition as required in Clause 4.1 "Sign Blanks".

Double Sided Acrylic Foam Tapes

- .9 Foam tapes must be double sided, medium firm, acrylic pressure sensitive adhesives that have high initial adhesion, good shear holding power and a demonstrated long-term holding strength. The tape must also be capable of withstanding extremely high or low temperatures and have characteristics similar to 3M VHB 4952 double sided acrylic foam tape.

Hinges

- .10 Hinges must comprise of a continuous brass, galvanised steel or stainless steel piano type hinge approximately 40 to 60 mm wide when in the open position with a 1 to 2 mm blade thickness and a 3 to 5 mm diameter stainless steel or brass hinge pin that is securely locked in position.

Retroreflective Material for Background and Legend

- .11 Class 1A, Class 1W, Class 1 and Class 2 retroreflective sheeting must conform to the requirements defined in AS 1906.1.
- .12 Details of the class of material to be used on Standard Signs are listed in Attachment R48A "Sign Materials - Legends and Background".
- .13 Details of the class of material to be used on specific road signs designated by a TES number are noted on the DPTI "Specific Road Signs-Specifications, South Australia" drawing. The Contractor must demonstrate that the luminance contrast ratios between legends and backgrounds is not less than that set out in Table B1, Appendix B, AS 1906.1.

Non-Retroreflective Material for Background and Legend

Paint

- .14 Paint must be compatible with the legend and background material, both in application and durability, and must meet the warranty requirement of the sign as set out in Table 8.3 "Warranty Performance Schedule".
- .15 Colours must approximate to that defined in AS 1743. Matt colours must have specular gloss value of:
- (a) 12 – 20 for an 85° head; or
 - (b) 8 – 12 for a 60° head,
- when measured in accordance with method 602.2 detailed in AS 1580.

Sheet Material

- .16 The material must be of uniform density and compatible with the material used for the legend and background both in application and durability. All sheeting must be applied with pressure sensitive adhesive or tack-free heat activated adhesive. Adhesive cast vinyl legend and background material or equivalent product may be used.

5. CERTIFICATION FROM RETROREFLECTIVE SHEETING MANUFACTURER

- .1 The sign manufacturer must provide the following details to support the sign performance warranty underwritten by the retroreflective sheeting manufacturer:
- (a) Report of the last audit of the manufacturing facility conducted by the retroreflective sheeting manufacturer to assess the Contractor's manufacturing performance.

- (b) Certification issued by the retroreflective sheeting manufacturer that the Contractor is currently eligible to offer a Sign Performance Warranty arrangement that is underwritten by the retroreflective sheeting manufacturer.
- .2 The Contractor must have procedures in place to satisfy the requirements of the retroreflective sheeting manufacturer for storage and handling of signs.

6. **MANUFACTURE OF SIGNS**

Sign Blanks

- .1 Sign blanks must be free of cracks, tears and other surface blemishes and the edges must be true and smooth. The face of each sign blank must be chemically cleaned and etched or mechanically abraded in accordance with AS 1627. The back of each sign blank must be rendered dull and non-reflective either by mechanical or chemical means.
- .2 Sign blanks must be fabricated from a single sheet of aluminium unless the sign is larger than the standard sheet size. Fingerblade signs must be manufactured from extruded aluminium with an extruded rib, top and bottom of the blade.

Multi-Piece Signs

- .3 Where the sign is of such a size as to require more than one full standard sheet of aluminium, a multi-piece sign must be made using the minimum number of sheets practicable.
- .4 A sign with more joints than necessary will not be accepted. All joints must be covered by a backing strip except for horizontal joints in sectioned signs. This backing strip must be fixed to the sign using double sided acrylic foam tapes or riveted to each sheet.
- .5 Double sided acrylic foam tapes must be applied in accordance with the manufacturer's recommended application procedure.

Sectioned Signs

- .6 Where the sign is of such a size that it is necessary for the sign to be manufactured, transported or installed in sections, it must be manufactured in accordance with Attachment R48C "Stiffener Joining Detail" (for vertical joints) and Attachment R48D "Sectioned Sign Joining" (for horizontal joints). Joints should not be made through legends or symbols wherever possible. Sectioned signs must be clearly marked for ease of assembly in the field.

Hinged Signs

- .7 Hinged signs, must be manufactured with the hinge running the full length of the hinged section of the sign. The hinge must be attached to the back of the sign such that when the sign is in the open position, only the pin roll is visible from the front of the sign.
- .8 Holes on the top and bottom or both sides of the sign must be positioned to accommodate a 38 mm wide padlock (supplied by others) when the sign is in the closed position.

Dimensions and Tolerances

- .9 The dimensions of the sign blank must be within ± 2.5 mm of those specified. The finished sign must be flat within a maximum allowable warp or twist of 5 mm/metre in any direction.
- .10 Backing strips must:
 - (a) be of uniform width of at least 50 mm wide over full length; and
 - (b) extend to within 25 mm of edge of sign.
- .11 Vertical backing strips must stop at each horizontal stiffener or horizontal backing strip and must butt against it with a gap of ≤ 1 mm.
- .12 Riveted backing strips, stiffeners and hinges must be:
 - (a) Secured by regularly spaced rivets to each side of the joint;
 - (b) Rivet spacing must not exceed 200 mm;
 - (c) The end rivets must be a maximum distance of 25 mm from each end; and
 - (d) A minimum of 2 rivets must be installed on each side of the joint.

- .13 Sections of multi-piece signs must be butted together with a maximum gap of 1 mm at any point along the joint.
- .14 Hinged sign plates must have sufficient clearance between the plates when the sign is in the closed position to clear the rivet heads. On sectioned signs, stiffeners must be placed along the edge of the butted joint and there must be a maximum gap of 1 mm at any point along the joint.
- .15 Stiffeners must comply with the following:
 - (a) butt joints must be ≤ 5 mm;
 - (b) each end of the stiffener must be 50 to 150 mm from the edge of the sign unless specified in Attachment R48B "Schedule of Hole and Stiffener Centre Locations"; and
 - (c) maximum panel overhang at the top and bottom of the sign must be an equal distance from the stiffener centres and must be in the range of between 50 to 150 mm.
- .16 Where "High Wind Signs" are specified on the Drawings, rivet spacing must not exceed 150 mm and at least 3 rivets must be installed on each side of the joint.

Provision for Mounting of Signs

Non-Reinforced Signs

- .17 Non-reinforced signs must be manufactured with square holes for mounting purposes. The holes must be cleanly punched 11 mm square (± 0.5 mm) to accept a 10 mm diameter cup head square neck bolt. The hole spacing must be in accordance with Attachment R48B "Schedule of Hole and Stiffener Centre Locations".

Reinforced Signs

- .18 All signs:
 - (a) with a plate thickness $t = 1.6$ mm and overall width > 1200 mm
 - (b) with a plate thickness $t = 2.0$ mm and overall width > 1400 mm;
- .19 must have stiffeners fixed to the rear of the sign in accordance with Attachment R48B "Schedule of Hole and Stiffener Centre Locations".
- .20 Where the length of the stiffener exceeds 6.0 m, joining of stiffening sections is permitted. Joined stiffening sections must be staggered so that the structural integrity of the sign is not compromised. Spacing must be in accordance with the stiffener centre guide in Attachment R48B "Schedule of Hole and Stiffener Centre Locations".
- .21 Where specified reinforcing for High Wind Category signs must be as shown on the drawings. Stiffeners must be attached to the sign blanks by rivets or double sided acrylic foam tapes.

Sectioned Signs

- .22 In addition to the requirements set out in Clause 6.6.2 "Reinforced Signs", sectioned signs must have stiffeners fixed along the horizontal joint of the two joining pieces in accordance Attachment R48D "Sectioned Sign Joining".

Temporary Signs

- .23 No provision for attachment is required for temporary signs.

Fingerblade signs

- .24 Spacers equal to the width of extrusion must be used when mounting fingerblade signs on 80 x 40 mm rectangular hollow section posts.

Sign Overlays

- .25 Sign overlays used to modify or amend a sign legend must be made from 1.6 mm thick aluminium sheet unless noted otherwise on the TES drawing.

Form of Letters and Numerals

- .26 All individual letters must have neat, clearly defined edges with smooth curves on round letters conforming to AS 1744.

Retroreflective Sign Background and Legend

Retroreflective Material

- .27 Retroreflective material must be applied to the sign blank in accordance with the Retroreflective Sheeting Manufacturer's recommendations. The material must be applied in one continuous piece. Retroreflective materials used as background and legends of signs must conform in colour and grade with the requirements of AS 1906.1.
- .28 Where sign dimensions exceed the standard retroreflective material width, joining of the material must be in accordance with Clause 6.9 "Material Joins".

Screening Ink and Electronic Cuttable Films

- .29 Coloured legends or backgrounds may be provided by using either:
 - (a) transparent screen process colours;
 - (b) opaque screen process colours;
 - (c) electronic cuttable films; or
 - (d) digital printing.
- .30 Legends must be manufactured by the retroreflective sheeting manufacturer to ensure compatibility and durability with the reflective sheeting.
- .31 The screen process colours or electronic cuttable films must be applied using materials and techniques recommended by the retroreflective sheeting manufacturer.
- .32 For digital printing only:
 - (a) matched component inks and printer devices recommended by the retro-reflective sheeting manufacturer must be used; and
 - (b) the ink and any protective coating must be compatible with the background material, both in application and durability.

Material Joins

- .33 Joins of the material must be in accordance with the Reflective Sheet Manufacturer's recommendations.

Non-Reflectorised Sign Background, Legend, Symbols and Borders

Background Paint

- .34 Where specified, the front of signs (background) must be painted using a 2-pack polyurethane paint as approved to APAS-2911. Surface preparation of the sign substrate and the primer to be used must be as specified by the finish coat manufacturer. All paints must be from the one manufacturer.
- .35 The colour of the background paint must be an approximate match to the appropriate colour as specified in AS 1743, Clause 10.1, when assessed in accordance with AS 1580.601.1. The specular gloss of the background paint must be less than 20%, when assessed in accordance with AS 1580.602.2.
- .36 Where required, the backs of signs must be painted as follows:
 - (a) degrease all surfaces in accordance with AS 1627.1;
 - (b) apply one coat of waterborne galvanized iron primer, as approved to APAS-0134; and
 - (c) apply two coats of flat or low gloss latex paint, as approved to APAS-0280/3.
- .37 The colour of the paint must be an approximate match to AS 2700, G61 Dark Green, unless otherwise specified, when assessed in accordance with AS 1580.601.1. All paints must be from the one manufacturer.
- .38 Where paint is used it must be applied with a minimum dry film thickness of 38 microns. Touching up of small areas by brush to fully match the spray painted surface must be permissible using the colour base and hardener mixture without reducer.

Sheet Material Application

- .39 All sheeting and films must be applied in accordance with the manufacturer's instructions so that that it is securely fixed to the sign and the surface is free of bubbles, wrinkles and blemishes.

Screening Ink and Electronic Cuttable Films

- .40 Legends may be manufactured using either opaque screen process colours or electronic cuttable films and the sign manufacturer must ensure compatibility and durability with the retroreflective sheeting.

The screen process colours or electronic cuttable films must be applied using materials and techniques recommended by the manufacturer of the retroreflective sheeting. Where joins in the cuttable films are required, they must be of the "butt-join" type and must overlap. Background material of the legend must be compatible in application and durability.

Reference Markings

- .41 Identification coding must be clearly and permanently stamped, engraved or printed on all signs. The coding must appear in characters 6 mm to 10 mm high. The coding may be made by stamping or engraving the rear of the sign, or by attaching a stamped or engraved 1.6 mm thick aluminium plate with rivets or double sided acrylic foam tape. Stamping and engraving must be carried out in such a manner that the front face of the sign is not damaged.
- .42 For rectangular signs, the coding must appear as near as practicable to the bottom rear left hand corner. For other shaped signs it must be positioned on or below the horizontal centre line and as near to the left rear edge as practicable.
- .43 For printed signs the code may be printed on the signface within the outer border strip as near as practicable to the bottom left hand corner – refer Attachment R48E "Sign Identification". Identification codes printed on the front of a sign must be encased under protective film to ensure the code remains legible for the life of the sign.
- .44 The format of the information must include:
 - (a) TES number or Sign Code;
 - (b) Sign Manufacturer's Name;
 - (c) Month and Year of Manufacture; and
 - (d) Manufacturer and Class of Retroreflective Material.

For example:

XYZ	11	17	3M1
Abbreviated to Signify Manufacturer	Month of Manufacture	Year of Manufacture	Abbreviated to Signify Retroreflective Sheeting Manufacturer and Grade of Retroreflective Sheeting

7. HANDLING OF SIGNS

- .1 All finished signs must be handled, transported and stored to prevent damage to the sign face or other components. Large guide and information signs must be adequately braced during transport to avoid buckling and rivet popping. Packaged signs must not be stored wet.
- .2 Signs may only be stored outdoors if no practical indoor alternative exists. If the signs are stored in outdoor facilities, the signs must be:
 - (a) Stored off the ground in an upright position;
 - (b) Supported to prevent damage to the face or sign blank;
 - (c) Free of transport packaging; and
 - (d) Well ventilated to prevent moisture build up on the face of the sign.
- .3 Moisture or condensation must not come into contact with the face of the sign. Signs with wet packages must immediately be removed and allow to dry completely.
- .4 Signs must not be stored in a high temperature or high humidity environment and must be appropriately protected for the storage conditions.

8. SIGN PERFORMANCE WARRANTIES

General

- .1 The Contractor must establish, in conjunction with the manufacturer, procedures for storage, delivery and erection to ensure continuity of the retroreflective sheeting manufacturer's warranty.
- .2 The Contractor must provide certification from the retroreflective sheeting manufacturer that in the event of a failure to the sign during the warranty period, the retroreflective sheeting manufacturer must repair or replace the faulty sign.

- .3 In the event of a defect in a sign which has been installed, the Contractor must either:
- remove, replace and reinstall the defective sign at its own expense without additional payment; or
 - if agreed between the parties, compensate the Principal for all additional costs necessary incurred by the Principal (including removal and reinstallation) as a consequence of the defective sign.
- .4 This warranty must not apply to signs that have failed *in* service as a result of vandalism, accidental damage or abnormal environmental conditions.

Sign Panel

- .5 The complete sign panel including all components thereon or attached except for the sign face or sheeting, must be guaranteed against any defects caused by failure of the components for a period of at least 36 months from the date of manufacture.
- .6 This warranty does not apply to signs that have failed in service as a result of vandalism, accidental damage or abnormal environmental conditions.

Sign Face or Sheeting

- .7 The Contractor must provide a manufacturer's guarantee the signs for the warranty period shown in the Table 8.3 "Warranty Performance Schedule". Where materials with different performance characteristics are combined, such as a guide sign, the warranty period applicable is determined by the warranted performance of the material with the minimum durability ranking of the combination.

<u>TABLE 8.3 WARRANTY PERFORMANCE SCHEDULE</u>			
Background Sheeting Class	Used in combination with	Warranted Outdoor Exposure	Warranted Retained CIL/m² Percentile ¹
Class 1W	Class 1A	10 years	80% ²
	Class 1W	10 years	
	Class 1	12 years	
	Electronic Cuttable Films	14 years	
	Screen printed colours	10 years	
	Fluorescent Yellow, Yellow/Green	10 years	
Class 1	Fluorescent Red/Orange	3 years	80% ²
	Class 1	12 years	
	Electronic Cuttable Films	14 years	
	Screen printed colours	10 years	
	Fluorescent Yellow, Yellow/Green	5 years	
Class 2	Fluorescent Red/Orange	3 years	50% ²
	Class 1A	7 years	
	Class 1W	10 years	
	Class 1	12 years	
	Electronic Cuttable Films	14 years	
	Fluorescent Yellow, Yellow/Green	10 years	

¹ Warranted retained brightness levels apply to reflective sheeting used for sign backgrounds, borders and legends.

² Retained CIL percentile is based on minimum CIL values for new reflective sheeting by Class for all of the combinations of Observation and Entrance Angles defined in relevant tables included in AS1906.1.

Non-Metallic Substrate Sign Blank and Sheeting

- .8 The combined manufacture of non-metallic substrate sign blank and sheeting as one item by the sign manufacturer must guarantee the warranty period shown in the Table 8.3 "Warranty Performance Schedule" for the combination sign.

9. VERIFICATION REQUIREMENTS AND RECORDS

.1 The Contractor must supply the following records:

CLAUSE REF.	SUBJECT	RECORD TO BE PROVIDED
8.	Sign manufacturer's warranty	Retro reflective warranty

ATTACHMENT R48A**SIGN MATERIALS - LEGENDS AND BACKGROUNDS**

SIGN SITUATION		SIGN BACKGROUND REFLECTIVE SHEETING CLASS AND COLOUR
Regulatory Signs		
1.1.1	Movement Series (R1)	Class 1 Legend & Background
1.1.2	Direction Series (R2)	Class 1 Legend & Background
1.1.3	Pedestrian Series (R3)	Class 1 Legend & Background
1.1.4	Speed Series (R4)	Class 1 Legend & Background
1.1.5	Parking Series (R5) Except R5-50, R5-51, R5-57 & R5-58	Non-reflective Legend & Background Class 1 Legend & Background
1.1.6	Miscellaneous Series (R6) Except R6-11 & R6-12	Class 1 Legend & Background Class 1W Legend & Background
1.1.7	Exclusive-use Lane Series (R7)	Class 1 Legend & Background
1.1.8	Bicycle/Pedestrian Series (R8)	Class 1 Legend & Background
1.1.9	Supplementary Plates for General Use (R9)	Class 1 Legend & Background
Warning Signs		
1.2.1	Alignment Series (W1)	Class 1 Yellow
1.2.2	Intersection & Junction Series (W2)	Class 1 Yellow
1.2.3	Advance warning of Traffic Control Device Series (W3)	Class 1 Yellow
1.2.4	Road Width, Low & Narrow Clearance Series (W4)	Class 1 Yellow
1.2.5	Road Obstacle Series (W5)	Class 1 Yellow
1.2.6	Pedestrian, School & Bicycle Series (W6) Except W6-1, W6-2, W6-3 & W6-SA106,	Class 1 Yellow Class 1 Fluorescent Yellow/Green
1.2.7	Railway Level Crossing Series (W7) Except W7-2 & W7-14	Class 1 Yellow Black on Class 1 White
1.2.8	Auxiliary Series (W8) Except W8-13, W14, W8-18, W8-19, W8-20, W8-22, W8-24, W8-25, W8-SA3, W8-SA5, W8-SA17, W8-SA23, W8-SA56, W8-SA104	Class 1 Yellow Fluorescent Yellow/Green
1.2.9	Other Warning Signs	Class 1 Yellow

Guide Signs (excluding TES Drawings)			
1.3.1	Direction Series (G6)	Black	Class 1 White
1.3.2	Service Series (G7) Except G7-SA122	Class 1 White	Class 1 Background
1.3.3	Route Marker Series (G8)	Class 1 White	Class 1 Brown
1.3.4	Traffic Instruction Series (G9)	Class 1 Legend	Class 1 Background
1.3.5	Kilometre Posts (G10)	Class 1 White	Class 1 Green
1.3.6	Tourist Series (G11)	Class 1 White	Class 1 Brown
Freeway Guide Series (excluding TES Drawings)			
1.4.1	Exit Direction Series (GE2)	Class 1 White	Class 1 Green
1.4.2	Information Series (GE6)	Class 1 White	Class 1 Green
1.4.3	Service Series (GE7)	Class 1 White	Class 1 Blue
1.4.4	Traffic Instruction Series (GE9)	Class 1 Legend	Class 1 Background
Temporary Signs			
1.5.1	Worker Protection Signs		Class 1A Orange Fluorescent
1.5.2	Other Temporary Signs		Class 1 Legend & Background Fluorescent Yellow/Green where specified
Hazard Markers			
1.6.1	Hazard Markers (D4) Except D4-6 and D4-SA50		Class 2 White Class 1 Yellow
Other			
1.7.1	Guide Post Marker		Class 1A Red/White
TES Signs			
1.8.1	As detailed on individual TES drawings		

ATTACHMENT R48B

SCHEDULE OF HOLE AND STIFFENER CENTRE LOCATIONS

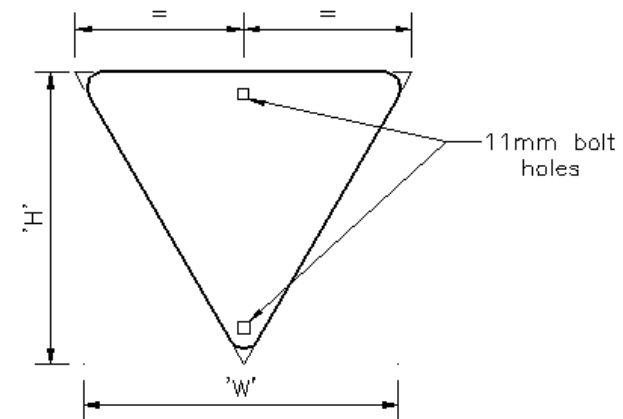
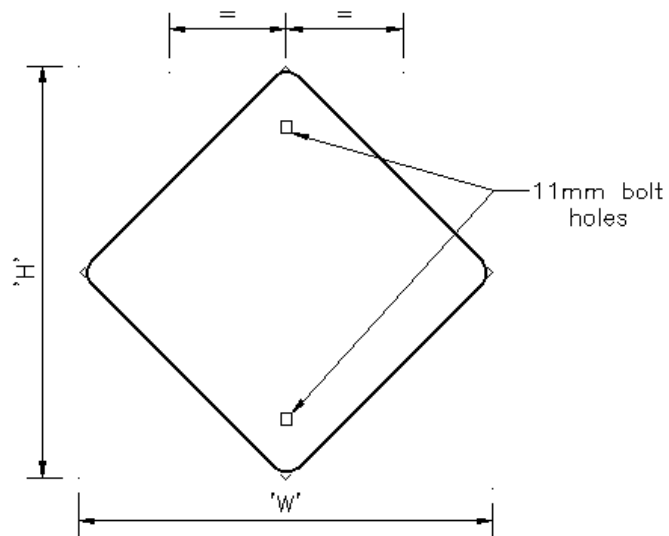
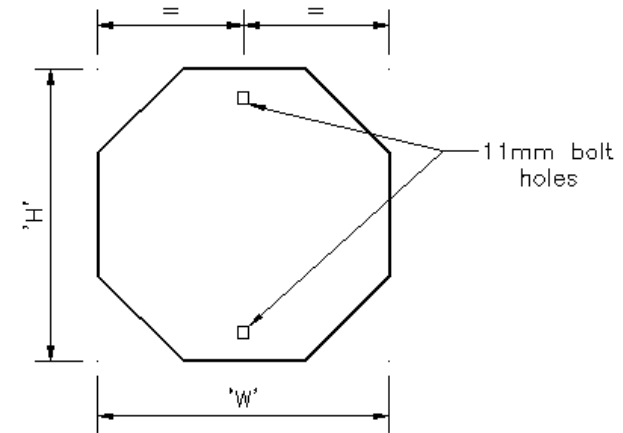
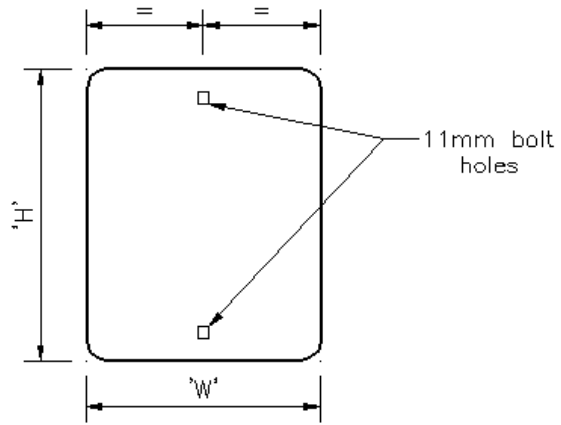

Overall Sign Size	Sign Height 'H'	Sign Width 'W'								Bolt Hole Spacing	No. of Holes	Stiffener Spacing	No. of Stiffeners
		< 1200				1201 - 1400		> 1401					
		Holes		Stiffener		Holes		Stiffener					
		Plate Thickness											
		1.6	2.0	1.6	2.0	1.6	2.0	1.6	2.0				
	100	Holes or Stiffeners to suit as required											
	150	Holes or Stiffeners to suit as required											
	180	Holes or Stiffeners to suit as required											
	200	Y	Y	Y	Y	N/A	Y	Y	Y	150	2	150	2
	210	Y	Y	Y	Y	N/A	Y	Y	Y	150	2	150	2
	215	Y	Y	Y	Y	N/A	Y	Y	Y	150	2	150	2
	225	Y	Y	Y	Y	N/A	Y	Y	Y	150	2	150	2
	230	Y	Y	Y	Y	N/A	Y	Y	Y	150	2	150	2
	240	Y	Y	Y	Y	N/A	Y	Y	Y	150	2	150	2
	250	Y	Y	Y	Y	N/A	Y	Y	Y	150	2	150	2
	300	Y	Y	Y	Y	N/A	Y	Y	Y	150	2	150	2
	350	Y	Y	Y	Y	N/A	Y	Y	Y	300	2	300	2
	360	Y	Y	Y	Y	N/A	Y	Y	Y	300	2	300	2
	370	Y	Y	Y	Y	N/A	Y	Y	Y	300	2	300	2
	375	Y	Y	Y	Y	N/A	Y	Y	Y	300	2	300	2
	390	Y	Y	Y	Y	N/A	Y	Y	Y	300	2	300	2
	400	Y	Y	Y	Y	N/A	Y	Y	Y	300	2	300	2
	420	Y	Y	Y	Y	N/A	Y	Y	Y	300	2	300	2

300 x 300	425	Y	Y	Y	Y	N/A	Y	Y	Y	300	2	300	2
	450	Y	Y	Y	Y	N/A	Y	Y	Y	300	2	300	2
	500	Y	Y	Y	Y	N/A	Y	Y	Y	300	2	300	2
	550	Y	Y	Y	Y	N/A	Y	Y	Y	450	2	450	2
	560	Y	Y	Y	Y	N/A	Y	Y	Y	450	2	450	2
	600	Y	Y	Y	Y	N/A	Y	Y	Y	450	2	450	2
450 x 450	635	Y	Y	Y	Y	N/A	Y	Y	Y	450	2	450	2
	675	Y	Y	Y	Y	N/A	Y	Y	Y	450	2	450	2
	700	Y	Y	Y	Y	N/A	Y	Y	Y	450	2	450	2
	750	Y	Y	Y	Y	N/A	Y	Y	Y	600	2	600	2
	800	Y	Y	Y	Y	N/A	Y	Y	Y	600	2	600	2
	820	Y	Y	Y	Y	N/A	Y	Y	Y	600	2	600	2
verall Sign Size	Sign Height 'H'	Sign Width								Bolt Hole Spacing	No. of Holes	Stiffener Spacing	No. of Stiffeners
		< 1200				1201 - 1400		> 1401					
		Holes		Stiffener		Holes		Stiffener					
		Plate Thickness											
		1.6	2.0	1.6	2.0	1.6	2.0	1.6	2.0				
		600 x 600	850	Y	Y	Y	Y	N/A	Y				
	900	Y	Y	Y	Y	N/A	Y	Y	Y	600	2	600	2
	990	Y	Y	Y	Y	N/A	Y	Y	Y	450	3	450	3
	1000	Y	Y	Y	Y	N/A	Y	Y	Y	450	3	450	3
	1050	Y	Y	Y	Y	N/A	Y	Y	Y	450	3	450	3
750 x 750	1060	Y	Y	Y	Y	N/A	Y	Y	Y	450	3	450	3
	1065	Y	Y	Y	Y	N/A	Y	Y	Y	450	3	450	3
	1067	Y	Y	Y	Y	N/A	Y	Y	Y	450	3	450	3
	1100	Y	Y	Y	Y	N/A	Y	Y	Y	450	3	450	3
	1125	Y	Y	Y	Y	N/A	Y	Y	Y	450	3	450	3
	1150	Y	Y	Y	Y	N/A	Y	Y	Y	450	3	450	3
	1170	Y	Y	Y	Y	N/A	Y	Y	Y	450	3	450	3
	1200	Y	Y	Y	Y	N/A	Y	Y	Y	450	3	450	3
900 x 900	1270	Y	Y	Y	Y	N/A	Y	Y	Y	600	3	600	3
	1300	Y	Y	Y	Y	N/A	N/A	Y	Y	600	3	600	3

	1334	Y	Y	Y	Y	N/A	N/A	Y	Y	600	3	600	3
	1350	Y	Y	Y	Y	N/A	N/A	Y	Y	600	3	600	3
	1400	Y	Y	Y	Y	N/A	N/A	Y	Y	600	3	600	3
	1420	Y	Y	Y	Y	N/A	N/A	Y	Y	600	3	600	3
	1440	Y	Y	Y	Y	N/A	N/A	Y	Y	600	3	600	3
	1485	Y	Y	Y	Y	N/A	N/A	Y	Y	600	3	600	3
	1500	Y	Y	Y	Y	N/A	N/A	Y	Y	600	3	600	3
	1600	N/A	N/A	Y	Y	N/A	N/A	Y	Y	N/A	N/A	TBD	3
	1650	N/A	N/A	Y	Y	N/A	N/A	Y	Y	N/A	N/A	TBD	4
1200 x 1200	1695	N/A	N/A	Y	Y	N/A	N/A	Y	Y	N/A	N/A	TBD	4
	1720	N/A	N/A	Y	Y	N/A	N/A	Y	Y	N/A	N/A	TBD	4
	1800	N/A	N/A	Y	Y	N/A	N/A	Y	Y	N/A	N/A	TBD	4
	1867	N/A	N/A	Y	Y	N/A	N/A	Y	Y	N/A	N/A	TBD	4
	1950	N/A	N/A	Y	Y	N/A	N/A	Y	Y	N/A	N/A	TBD	4

Overall Sign Size	Sign Height 'H'	Sign Width								Bolt Hole Spacing	No. of Holes	Stiffener Spacing	No. of Stiffeners
		< 1200				1201 - 1400		> 1401					
		Holes		Stiffener		Holes		Stiffener					
		Plate Thickness											
		1.6	2.0	1.6	2.0	1.6	2.0	1.6	2.0				
	2000	N/A	N/A	Y	Y	N/A	N/A	Y	Y	N/A	N/A	TBD	4
	2015	N/A	N/A	Y	Y	N/A	N/A	Y	Y	N/A	N/A	TBD	4
	2020	N/A	N/A	Y	Y	N/A	N/A	Y	Y	N/A	N/A	TBD	4
	2100	N/A	N/A	Y	Y	N/A	N/A	Y	Y	N/A	N/A	TBD	4
	2250	N/A	N/A	Y	Y	N/A	N/A	Y	Y	N/A	N/A	TBD	5
	2350	N/A	N/A	Y	Y	N/A	N/A	Y	Y	N/A	N/A	TBD	5
	2400	N/A	N/A	Y	Y	N/A	N/A	Y	Y	N/A	N/A	TBD	5
	2550	N/A	N/A	Y	Y	N/A	N/A	Y	Y	N/A	N/A	TBD	5
	2700	N/A	N/A	Y	Y	N/A	N/A	Y	Y	N/A	N/A	TBD	5
	2850	N/A	N/A	Y	Y	N/A	N/A	Y	Y	N/A	N/A	TBD	6
	2950	N/A	N/A	Y	Y	N/A	N/A	Y	Y	N/A	N/A	TBD	6
	3000	N/A	N/A	Y	Y	N/A	N/A	Y	Y	N/A	N/A	TBD	6
	3150	N/A	N/A	Y	Y	N/A	N/A	Y	Y	N/A	N/A	TBD	6

	3300	N/A	N/A	Y	Y	N/A	N/A	Y	Y	N/A	N/A	TBD	6
	3450	N/A	N/A	Y	Y	N/A	N/A	Y	Y	N/A	N/A	TBD	7
	3600	N/A	N/A	Y	Y	N/A	N/A	Y	Y	N/A	N/A	TBD	7
	3750	N/A	N/A	Y	Y	N/A	N/A	Y	Y	N/A	N/A	TBD	7
	3900	N/A	N/A	Y	Y	N/A	N/A	Y	Y	N/A	N/A	TBD	7
	4050	N/A	N/A	Y	Y	N/A	N/A	Y	Y	N/A	N/A	TBD	7
	4200	N/A	N/A	Y	Y	N/A	N/A	Y	Y	N/A	N/A	TBD	8
	4350	N/A	N/A	Y	Y	N/A	N/A	Y	Y	N/A	N/A	TBD	8
	4500	N/A	N/A	Y	Y	N/A	N/A	Y	Y	N/A	N/A	TBD	8
	4650	N/A	N/A	Y	Y	N/A	N/A	Y	Y	N/A	N/A	TBD	9
	4800	N/A	N/A	Y	Y	N/A	N/A	Y	Y	N/A	N/A	TBD	9
	4950	N/A	N/A	Y	Y	N/A	N/A	Y	Y	N/A	N/A	TBD	9

- Dimensions to the centre of stiffener or bolt holes;
- Stiffener spacing to be equidistant using required number of stiffeners for sign heights marked 'TBD' (To Be Determined);
- Refer to TES 12186 for additional stiffener requirements needed for gantry and overhead mounted signs.

ATTACHMENT R48C

STIFFENER JOINING DETAIL

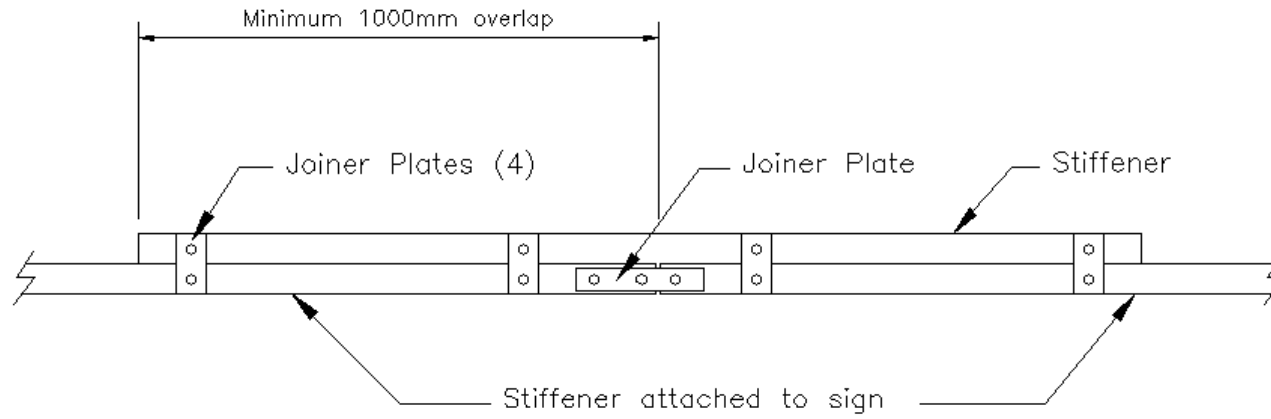

A minimum overhanging length of 1000 mm is required for the stiffeners at vertical joins.

ATTACHMENT R48D

SECTIONED SIGN JOINING

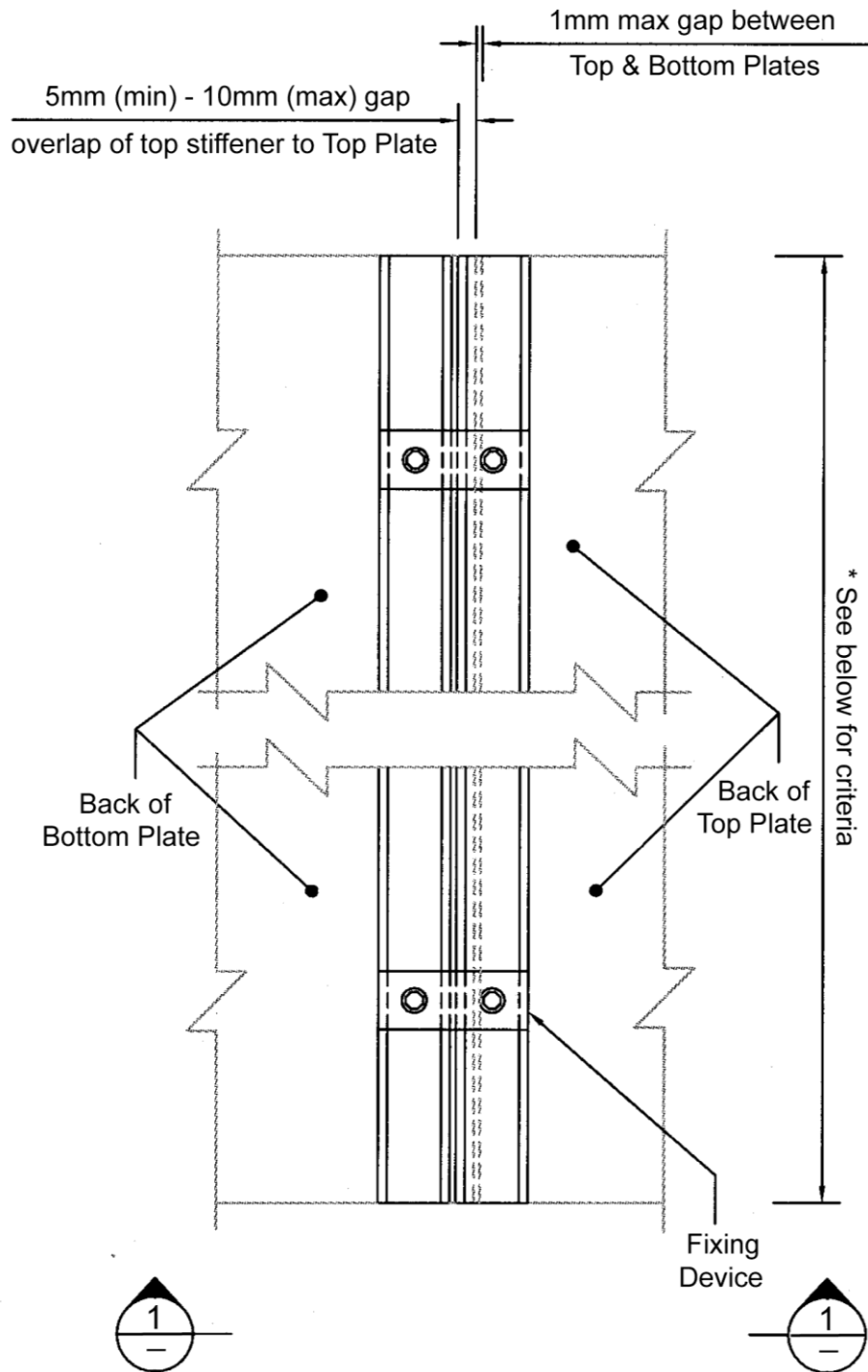

NOTE : * = > 2000 use a minimum of 3 Fixing Devices
< 2000 use 2 Fixing Devices

PLAN

SCALE 1:15

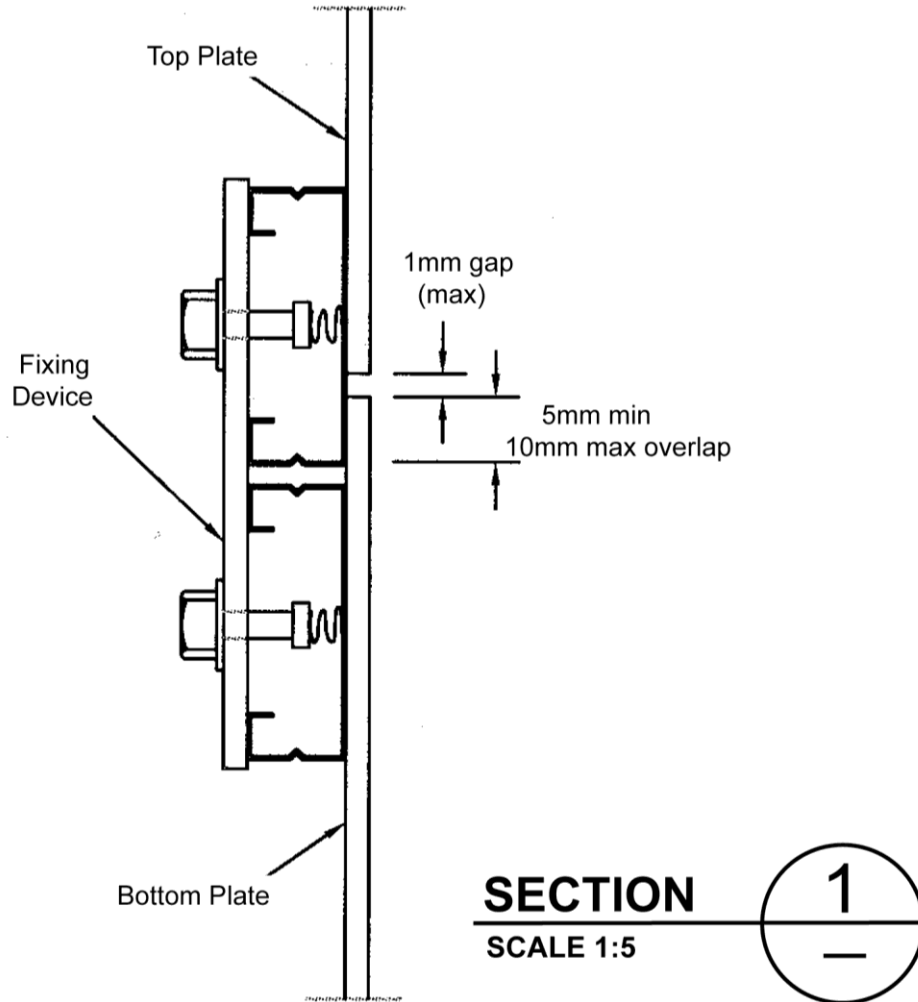

ATTACHMENT R48E

SIGN IDENTIFICATION

